

Dual Operation Amplifiers

General Description

The LM358 consists of two independent, high gain, internally frequency compensated operational amplifiers which were designed specifically to operate from a single power supply over a wide range of voltages. Operation from split power supplies is also possible and the low power supply current drain is independent of the magnitude of the power supply voltage.

Application areas include transducer amplifiers, dc gain blocks and all the conventional op amp circuits which now can be more easily implemented in single power supply systems. For example, the LM358 can be directly operated off of the standard +5V power supply voltage which is used in digital systems and will easily provide the required interface electronics without requiring the additional $\pm 15V$ power supplies.

Unique Characteristics

- In the linear mode the input common-mode voltage range includes ground and the output voltage can also swing to ground, even though operated from only a single power supply voltage.
- The unity gain cross frequency is temperature compensated.
- The input bias current is also temperature compensated.

Advantages

- Two internally compensated op amps
- Eliminates need for dual supplies
- Allows direct sensing near GND and V_{OUT} also goes to GND
- Compatible with all forms of logic
- Power drain suitable for battery operation
- Pin-out same as LM1558/LM1458 dual op amp

Features

- Internally frequency compensated for unity gain
- Large dc voltage gain: 100 dB
- Wide bandwidth (unity gain): 1 MHz (temperature compensated)
- Wide power supply range:
 - Single supply: 3V to 32V
 - or dual supplies: $\pm 1.5V$ to $\pm 16V$
- Very low supply current drain (500 μA)—essentially independent of supply voltage
- Low input offset voltage: 2 mV
- Input common-mode voltage range includes ground
- Differential input voltage range equal to the power supply voltage
- Large output voltage swing: 0V to $V^+ - 1.5V$

Voltage Controlled Oscillator (VCO)

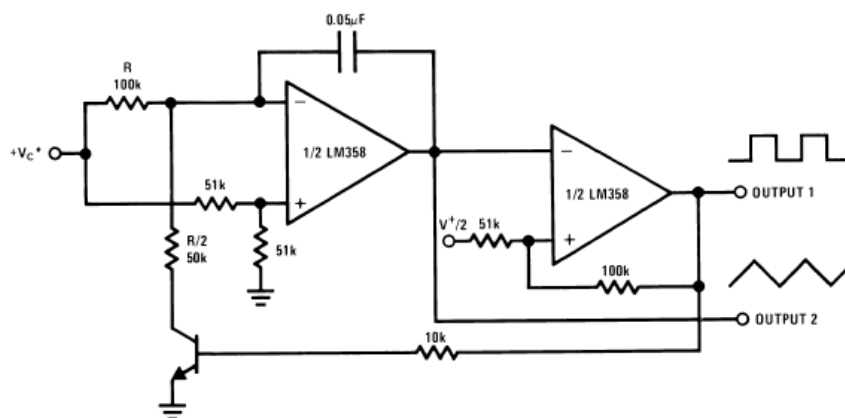

electrical characteristics at specified free-air temperature, V_{CC} = 5 V (unless otherwise noted)

PARAMETER	TEST CONDITIONS*	LM358			UNIT	
		MIN	TYP	MAX		
V _{IO} Input offset voltage	V _{CC} = 5 V to MAX, V _{IC} = V _{ICR} min, V _O = 1.4 V	25 °C		3	7	mV
		Full range			9	
αV _{IO} Average temperature coefficient of input offset voltage		Full range		7		μV/°C
I _{IO} Input offset current	V _O = 1.4 V	25 °C		2	50	nA
		Full range			150	
αI _{IO} Average temperature coefficient of input offset current		Full range		10		pA/°C
I _{IB} Input bias current	V _O = 1.4 V	25 °C		-20	-250	nA
		Full range			-500	
V _{ICR} Common-mode input voltage range	V _{CC} = 5 V to MAX	25 °C	0 to V _{CC} - 1.5			V
		Full range	0 to V _{CC} - 2			
V _{OH} High-level output voltage	R _L ≥ 2 kΩ	25 °C	V _{CC} - 1.5			V
	V _{CC} = MAX, R _L = 2 kΩ	Full range	26			
	V _{CC} = MAX, R _L ≥ 10 kΩ	Full range	27	28		
V _{OL} Low-level output voltage	R _L ≥ 10 kΩ	Full range		5	20	mV
A _{VD} Large-signal differential voltage amplification	V _{CC} = 15 V, V _O = 1V to 11 V, R _L ≥ 2 kΩ	25 °C	25	100		V/mV
		Full range	15			
CMRR Common-mode rejection ratio	V _{CC} = 5 V to MAX, V _{IC} = V _{ICR} min	25 °C	65	80		dB
k _{SVR} Supply voltage rejection ratio (ΔV _{CC} /ΔV _{IO})	V _{CC} = 5 V to MAX	25 °C	65	100		dB
V _{O1} /V _{O2} Crosstalk attenuation	f = 1 kHz to 20 kHz	25 °C		120		dB
I _O Output current	V _{CC} = 15 V, V _{ID} = 1 V, V _O = 0	25 °C	-20	-30		mA
		Full range	-10			
	V _{CC} = 15 V, V _{ID} = -1 V, V _O = 15 V	25 °C	10	20		
		Full range	5			
	V _{ID} = -1 V, V _O = 200 mV	25 °C	12	30		μA
I _{OS} Short-circuit output current	V _{CC} at 5 V, GND at -5 V, V _O = 0	25 °C		±40	±60	mA
I _{CC} Supply current (two amplifiers)	V _O = 2.5 V, No load	Full range		0.7	1.2	mA
	V _{CC} = MAX, V _O = 0.5V _{CC} , No load	Full range		1	2	

* All characteristics are measured under open-loop conditions with zero common-mode input voltage unless otherwise specified. «MAX» V_{CC} for testing purposes is 30 V. Full range is 0 °C to 70 °C.

Connection Diagrams

LM358N

DIP-8

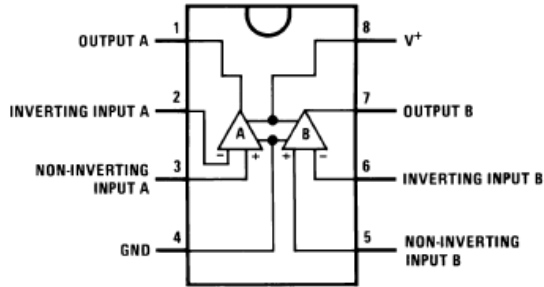

Physical Dimensions inches (millimeters) unless otherwise noted (Continued)

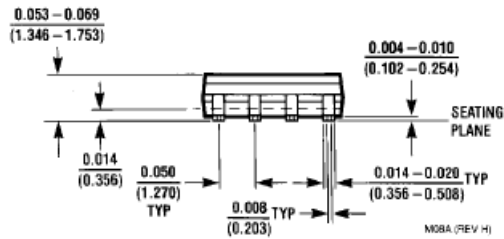
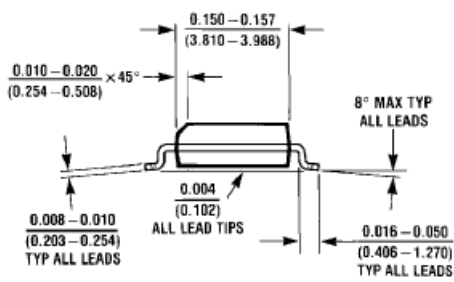
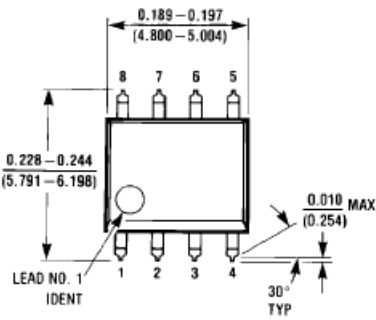

SO-8

LM358M